

4 Technical Data

4.1 General Specifications BPS 34

Optical Data

Light source	Laser diode 650nm
Scanning rate	1000scans/sec.

Measurement data

Reproducible accuracy	±1 (2) mm
Integration time	16 (8) ms
Measurement value output	500 values/sec.
Refresh time	2ms
Scanning depth	60 ... 140 mm

Electrical data

Interface type	Profibus DP
Service interface	RS232 with fixed data format, 9600Bd, 8 data bits, no parity, 1 stop bit
Ports	1 switching output, 1 switching input
LED green	device ready (Power On)
Operating voltage	10 ... 30V
Power consumption	5W

Mechanical data

Protection class	IP 65
Weight	400 g
Dimensions (W x H x D)	120 x 90 x 43mm
Housing	diecast aluminium

Environmental data

Operation w/o optics heating	0°C ... +40°C
Operation with optics heating	-30°C ... +40°C
Storage	-20°C ... +60°C
Air humidity	max. 90% rel. humidity, non-condensing
Vibration	IEC 68.2.6 IEC 68.2.27 (shock) IEC 801
Electromagnetic compatibility	acc. to IEC 60947-5-2

Barcode band

Max. length (measurement length)	10000m
Ambient temperature	-40°C ... +120°C
Mech. properties	scratch and wipe resistant UV resistant moisture resistant partly chemical resistant

Table 4.1: General Specifications

4.2 LED indicators

BPS 34

A BPS 34 internal green LED indicates in the reading window whether or not the supply voltage is present.

MS 34 103 / MS 34 105

On top of the modular hood with integrated connectors a red/green status LED is located between the M12 connectors DP IN and DP Out. It indicates the state of the Profibus connection.

State	Meaning
off	voltage off
green flashing	initialisation of the device, establishment of the PROFIBUS communication
green, continuous light	data operation
red, flashing	error on PROFIBUS, error can be resolved by a reset
red, continuous light	error on PROFIBUS, error cannot be resolved by a reset
orange, continuous light	SERVICE operation active

Table 4.2: LED states MS 34 103 / MS 34 105

4.3 Device Construction and Components

A modular hood with integrated connectors of the type MS 34 103 or MS 34 105 is always part of a BPS 34. The purpose of both hoods is to connect the BPS 34 to the Profibus. For this, they feature one Profibus IN and one Profibus OUT connection each, as well as an internal switch for address setting.

If only the connection to the Profibus is intended, type MS 34 103 is sufficient.

If, in addition, switching input and output or a modular service display are to be connected, an MS 34 105 is required. Although switching inputs and outputs are available on the voltage supply connector, the switching inputs of the MS 34 105 have the advantage that a standard sensor connector can be used.



Figure 4.1: BPS 34 with MS 34 105

4.4 Dimensioned and Connection Drawings

BPS 34

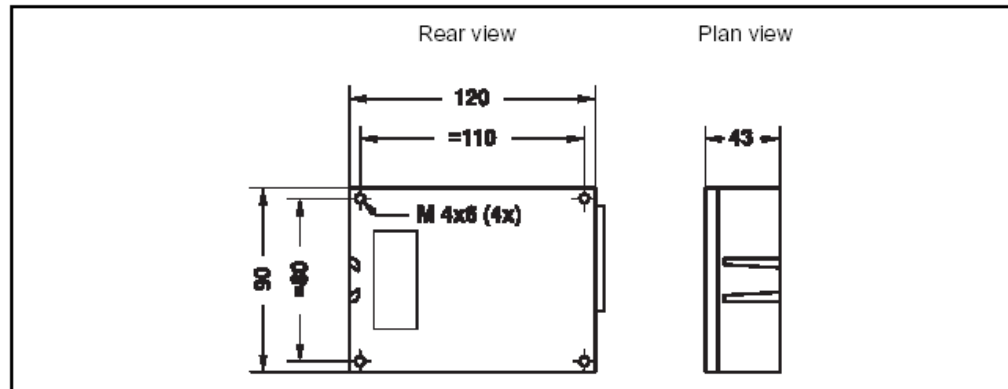

Figure 4.2: Dimensioned drawing BPS 34

MS 34 103 / MS 34 105

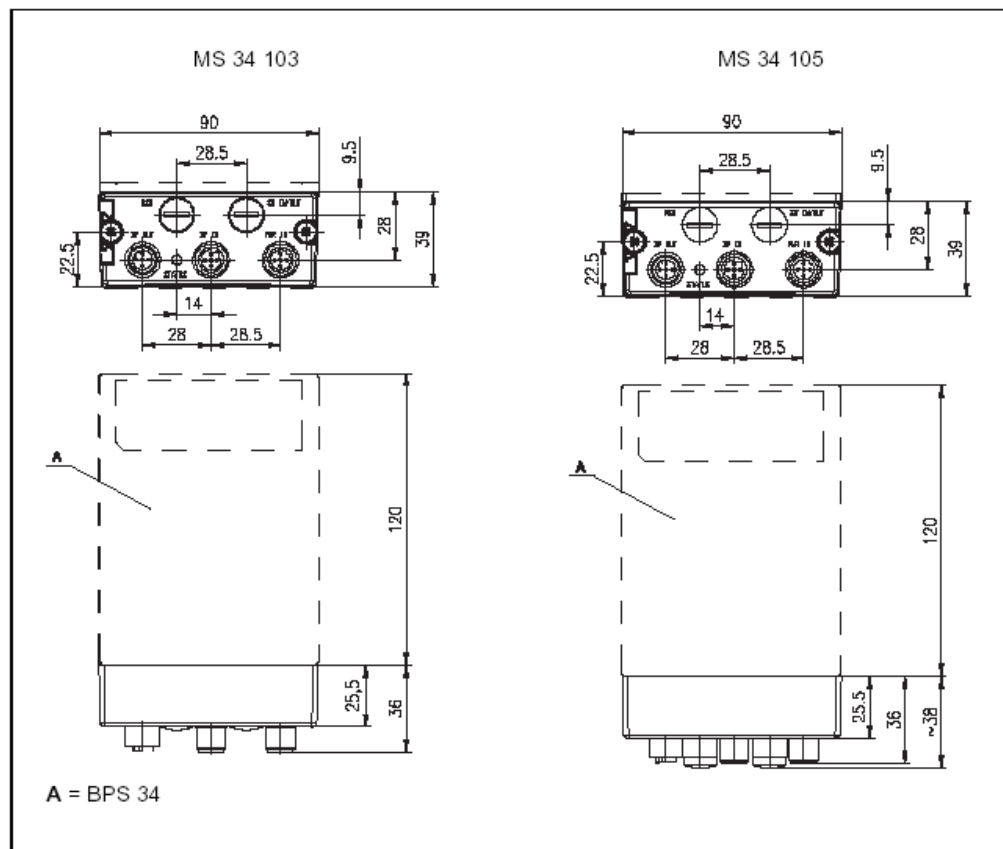

Figure 4.3: Dimensioned drawing MS 34 103 / MS 34 105

Scanning curve BPS 34

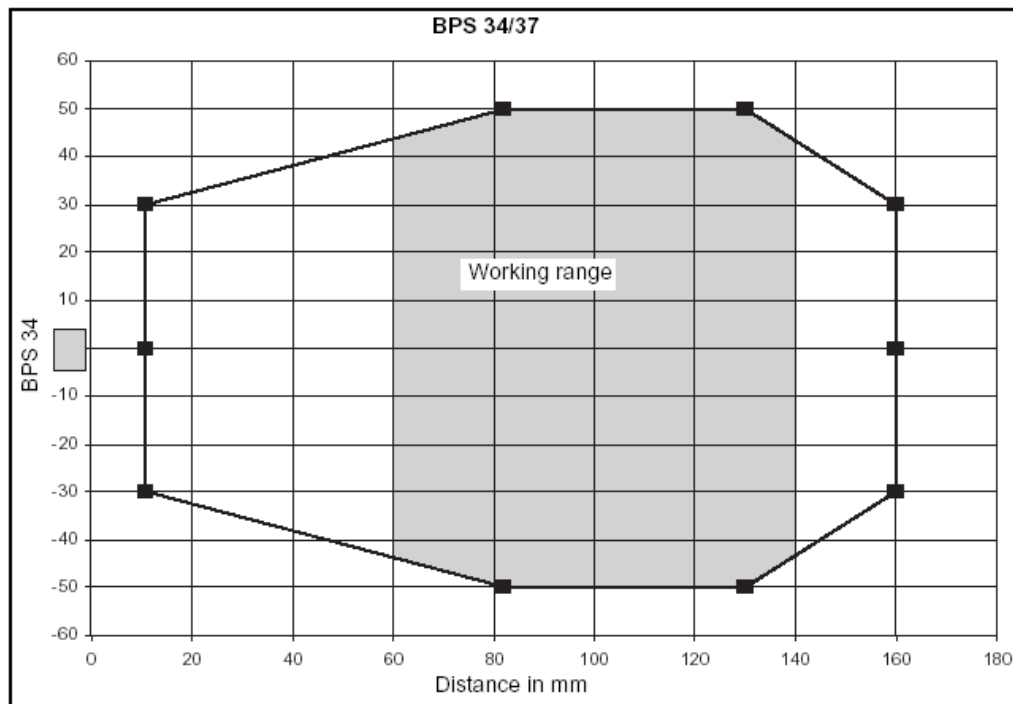

Figure 4.4: Scanning curve BPS 34

5 Accessories / Order Designation

5.1 Accessories



Notice!

Products from Leuze electronic GmbH & Co. can be ordered from any of the sales and service offices listed on the back page of this operating manual.

Symbol	Order No.	Short Description
MS 34 103	500 37230	Modular hood with integrated connectors for BPS 34 with three M12 connectors
MS 34 105	500 37231	Modular hood with integrated connectors for BPS 34 with five M12 connectors
MSD 1 101	500 37232	Modular service display MSD 1 101 for BPS 34 with 8-pin M12 connector
BT 56	500 27375	Mounting device with dovetail for rod
KB 034 - 2000	500 37543	Connection cable between MS 34 105 and MSD 1 101, length: 2m

Table 5.1: Accessories / Order Designation

5.1.1 Modular Service Display MSD 1 101

The modular service display MSD 1 101 is used to display device messages or the data that has been read.

- The device has a service interface in the form of a 9-pin sub-D connector (pin assignment: 2=Rx/D, 3=Tx/D, 5=GND).
Transmission in the standard Leuze format 9600/8/Non/1 frame STX/.../CR/LF.
- Connection to the PC via null modem cable
- One can access **all** parameters of the BPS 34 via the service interface.
- Operating mode switch: service operation/standard operation
- Display



Attention!

If parameters are changed that can also be set via the Profibus, they are overwritten with the parameter setting defined in the Profibus after Profibus start-up. If device or module parameters are to be changed permanently, then they must be set in the Profibus project.

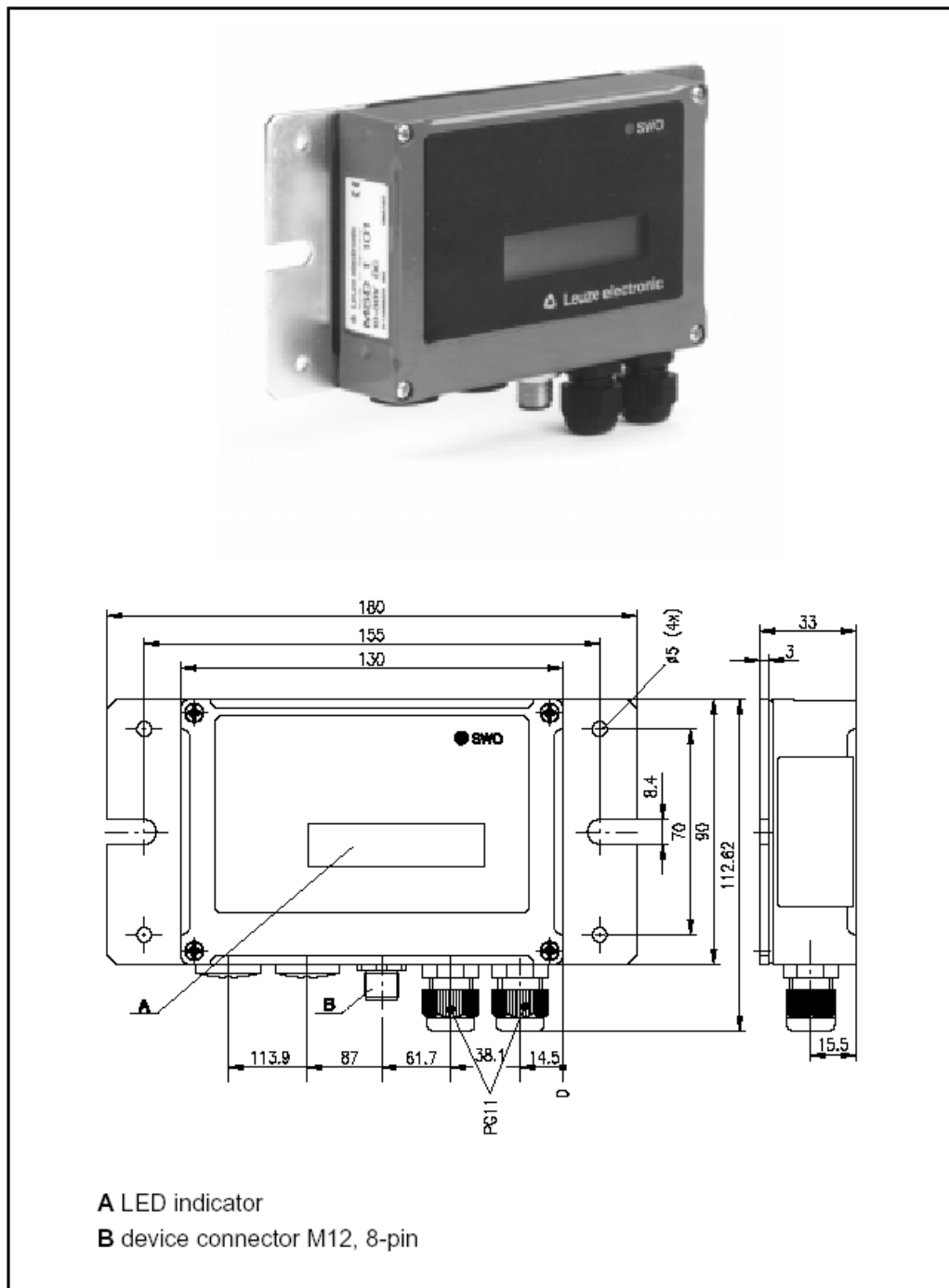

Figure 5.1: Modular Service Display MSD 1 101

5.1.2 Fastening Accessories

The mounting unit BT 56 is available for mounting the BPS 34. It is designed for rod installation.

Mounting device BT 56

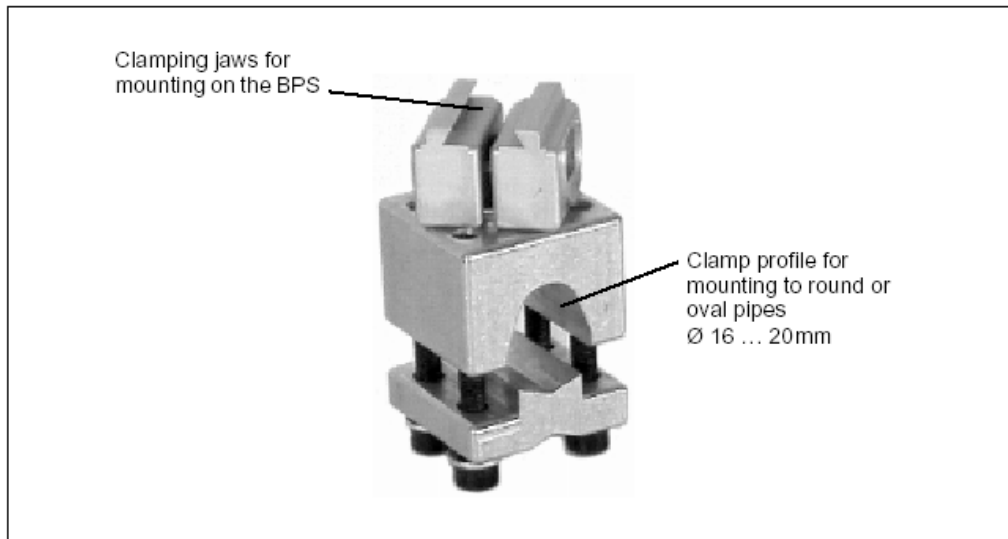

Figure 5.2: Mounting device BT 56

5.1.3 Connection cable

A special connection cable of 2 m length is available for the connection between MS 34 105 and MSD 1 101.